

E-ViPO[®]

MVHR | HEAT RECOVERY VENTILATION UNIT
USER MANUAL | ENGLISH VERSION OV1.2
MVHR INSTALLATION & OPERATION

MVHR SERIES CS MODEL

CS200-ERV-B-Z-EC
CS250-ERV-B-Z-EC
CS300-ERV-B-Z-EC
CS250-ERV-B-Z-AC

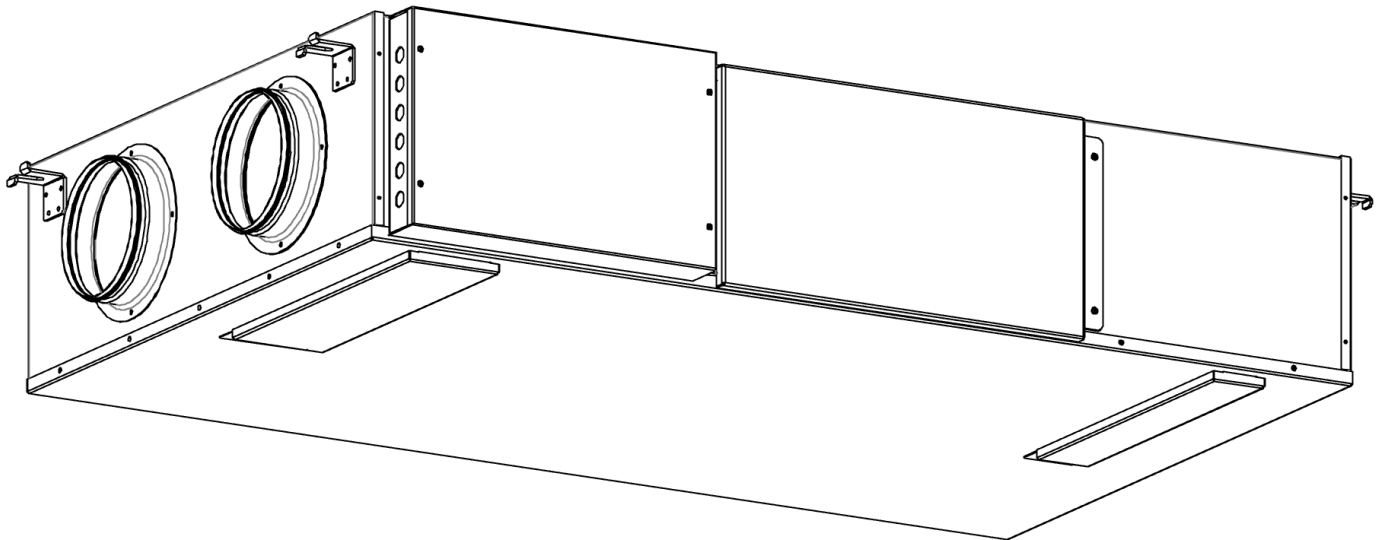

CONTENTS

01/ SAFETY REQUIREMENT & WARNING

- 1.1 General
- 1.2 Storage & Transportation
- 1.3 Precaution for Installation & Operation

02/ OPERATING PRINCIPLE OF THE VENTILATION UNIT

- 2.1 Heat Recovery Mode
- 2.2 Summer Bypass Mode

03/ MVHR SERIES CS MODEL

- 3.1 Delivery Set
- 3.2 Technical Specification
- 3.3 Product Structure
- 3.4 Overall Dimension

04/ MVHR INSTALLATION INSTRUCTION & OPERATION GUIDE

- 4.1 Recommendation for Installation
- 4.2 Installation of the Ventilation Unit
- 4.3 Inspection before Trial Operation
- 4.4 The Ventilation Unit Commissioning

05/ FILTER & HEAT EXCHANGER MAINTAINENCE GUIDE

- 5.1 The G4 Supply Filter or Extract Filter Wash Cleaning & Replacement Guide
- 5.2 The F8 Supply Filter Vacuum Cleaning & Replacement Guide
- 5.3 The Heat Exchanger Vacuum Cleaning & Wash Cleaning Guide

01/ SAFETY REQUIREMENT & WARNING

- Users should entrust professional HVAC engineers to carry out the ventilation unit selection and engineering design, and hire experienced construction units to complete the construction of the project. The electrical, technical, design and construction shall be carried out in accordance with the relevant applicable local and national norms, standards and regulations. Users who do not meet the above conditions can complete the ventilation unit installation by referring to the instructions in this manual. If the ventilation unit is not installed according to the specified requirements, the ventilation unit may not work properly

1.1 General

- Keep the user manual properly throughout the entire service life of the ventilation unit
- Do not disassemble, repair or modify the ventilation unit at will without the advice of professional personnel
- If the power cord is damaged, it is necessary to use a dedicated cord
- It is necessary to buy the dedicated components from its supplier or maintenance department

- Ventilation unit must be disconnected from the power supply before cleaning or other maintenance takes place
- If there is gas leakage in the house, open the windows for ventilation, do not use the ventilation unit to avoid danger
- Flammable materials or objects that prone to fire should not be stored in the same area with the ventilation unit
- Explosive substances should not be stored in the same area with the ventilation unit
- Contact the supplier when there is abnormal operation from the ventilation unit such as abnormal sound or smell
- Avoid the transferred air flows in contact with the fire sources such as open flame, oils or chemicals
- Air duct should not be blocked when the ventilation unit is operating
- Do not step or place any objects on the ventilation unit
- Keep the ventilation unit in dry and ventilated area
- Avoid direct sunlight or wet conditions to the ventilation unit, otherwise it may cause the ventilation unit damage
- Installation, operation, maintenance should be carried out by well trained professional expert or qualified personnel
- If the outdoor dust is too much such as during sandstorm weather, do not use the ventilation unit for ventilation

1.2 Storage & Transportation

- After the ventilation unit delivered to the construction site, it must be properly kept
- The protective carton used for the ventilation unit during transportation shall continue to be used during storage
- Handle the ventilation unit with care during storage and transportation
- Product shall be stored in the original packing box at temperature from +5°C to +40°C in dry and ventilated area
- Prevent the product from corrosion and deformation
- Transportation should avoid causing possible damages to the ventilation unit including during loading or unloading
- Protective measures must be taken to prevent adverse effects of severe weather and moving shocks during transportation
- Protective measures must be taken to prevent the construction dust and sundries from entering the ventilation unit
- Corresponding measures must be taken to avoid affecting the product performance

1.3 Precaution for Installation & Operation

- Read the user manual and the requirements carefully before installation or operation takes place
- Corresponding measures must be taken to prevent the occurrence of dangerous operations
- Power ON is strictly prohibited before commissioning
- Ventilation unit should not be operating outside the temperature range recommended in the user manual
- Ventilation unit should not be operating outside the relative humidity range recommended in the user manual
- Electricity voltage of the ventilation unit is 230V~
- Do not install the ventilation unit on flammable or combustible objects or in explosive environments
- Incorrect wiring or operation will lead to serious damage to the ventilation unit, personal safety accidents or injuries
- Make sure that the power supply is disconnected before removing the protective case, installation or operation
- Do not wet the ventilation unit, control panel or other parts during installation, operation or maintenance
- Children or persons with reduced physical, mental or sensory capacities should not be allowed to operate

- Installation location should take into account of the possible access by children to prevent accidents from happening
- Use of tools or materials should meet the specific requirements for installation

02/ OPERATING PRINCIPLE OF THE VENTILATION UNIT

2.1 Heat Recovery Mode

- ▣ The outdoor fresh air delivered into the room by the supply fan after passing through the filter and the heat exchanger, and the indoor contaminated air discharged to the outside by the extract fan after passing through the filter and the heat exchanger. The two air streams exchange heat and energy in the heat exchanger, that is, the incoming fresh air absorbs the cold or heat contained in the contaminated air discharged, so that the temperature of the fresh air can be increased or decreased, so as to achieve the purpose of energy saving, that is, the energy usage and energy cost of using other heater or cooler equipment indoor can be reduced. In this way, fresh air can be delivered into the room without obvious change of indoor temperature. The fresh air and the exhaust air cross each other in the channels on both sides of the partition plate to exchange heat. The two air flows separated by a partition, not in direct contact, and heat exchange carried out through the partition, so there is no cross-contamination. There are no moving parts inside the heat exchanger, with stable performance and no additional energy consumption

2.2 Summer Bypass Mode

- ▣ When the ventilation unit is in bypass mode, the outdoor fresh air goes through the bypass channel without passing through the heat exchanger, without crossing the air with indoor contaminated air to exchange heat and energy. In this way, the outdoor fresh air with comfortable temperature can be directly delivered into the room without going through the heat recovery process, that is, achieving the free-cooling for the indoor

03/ MVHR SERIES CS MODEL

3.1 Delivery Set

MVHR UNIT - 1 PC

MVHR USER MANUAL - 1 PC

3.2 Technical Specification

Model	CS200-ERV-B-Z-EC	CS250-ERV-B-Z-EC	CS300-ERV-B-Z-EC
Fan Motor Type	EC	EC	EC
Max. Airflow [m ³ /h]	270	310	360
Max. Airflow [m ³ /h]	200 @ 100Pa	250 @ 100Pa	300 @ 100Pa
Rated Max. Power	230V~50Hz, 73W, 0.6A	230V~50Hz, 102W, 0.7A	230V~50Hz, 142W, 1A
Power Input Range	200-240V~, 50/60Hz	200-240V~, 50/60Hz	200-240V~, 50/60Hz
Weight [kg]	49.3	49.3	49.3
Extract Filter	G4	G4	G4
Supply Filter	G4	G4	G4
Supply Filter	F8 (Optional)	F8 (Optional)	F8 (Optional)
Max. Static Pressure [Pa]	365	415	410

Heat Exchanger Type	Counter-flow	Counter-flow	Counter-flow
Heat Exchanger Material	Enthalpy	Enthalpy	Enthalpy
Heat Recovery Efficiency [%]	90-96	87-96	84-96
Internal Insulation Material	Polyethylene Foam	Polyethylene Foam	Polyethylene Foam
Case Material	Coated Sheet Steel	Coated Sheet Steel	Coated Sheet Steel
Transferred Air Temperature [°C]	(-25 to +50)	(-25 to +50)	(-25 to +50)
Operating Ambient Temperature [°C]	(+5 to +40)	(+5 to +40)	(+5 to +40)
Operating Ambient Relative Humidity [%]	<80	<80	<80
Connected Air Duct Diameter [mm]	150	150	150

* A 10% reduction of supply airflow may occur when Supply Filter F8 applied

Model	CS250-ERV-B-Z-AC
Fan Motor Type	AC
Max. Airflow [m3/h]	350
Max. Airflow [m3/h]	250 @ 100Pa
Rated Max. Power	230V~50Hz, 172W, 0.8A
Power Input Range	200-240V~, 50/60Hz
Weight [kg]	49.3
Extract Filter	G4
Supply Filter	G4
Supply Filter	F8 (Optional)
Max. Static Pressure [Pa]	360
Heat Exchanger Type	Counter-flow
Heat Exchanger Material	Enthalpy
Heat Recovery Efficiency [%]	86-96
Internal Insulation Material	Polyethylene Foam
Case Material	Coated Sheet Steel
Transferred Air Temperature [°C]	(-25 to +50)
Operating Ambient Temperature [°C]	(+5 to +40)
Operating Ambient Relative Humidity [%]	<80
Connected Air Duct Diameter [mm]	150

* A 10% reduction of supply airflow may occur when Supply Filter F8 applied

3.3 Product Structure

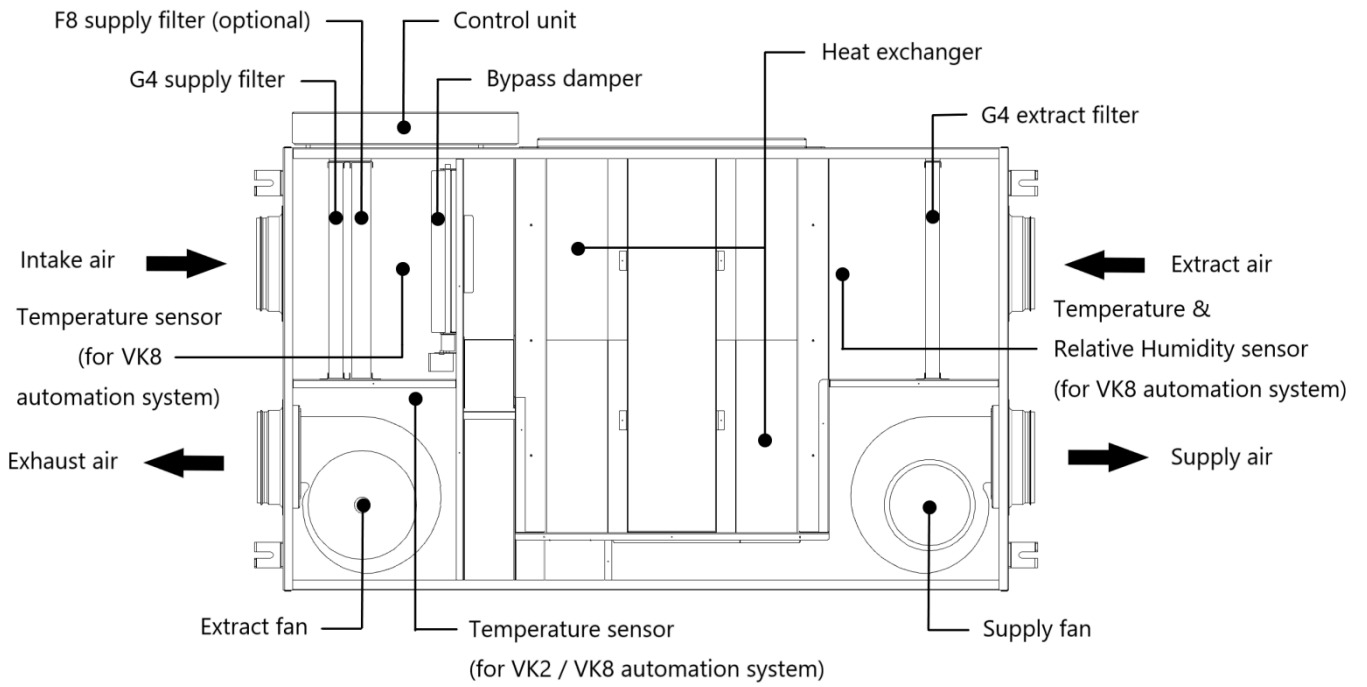

3.4 Overall Dimension

❖ Dimension in (mm)

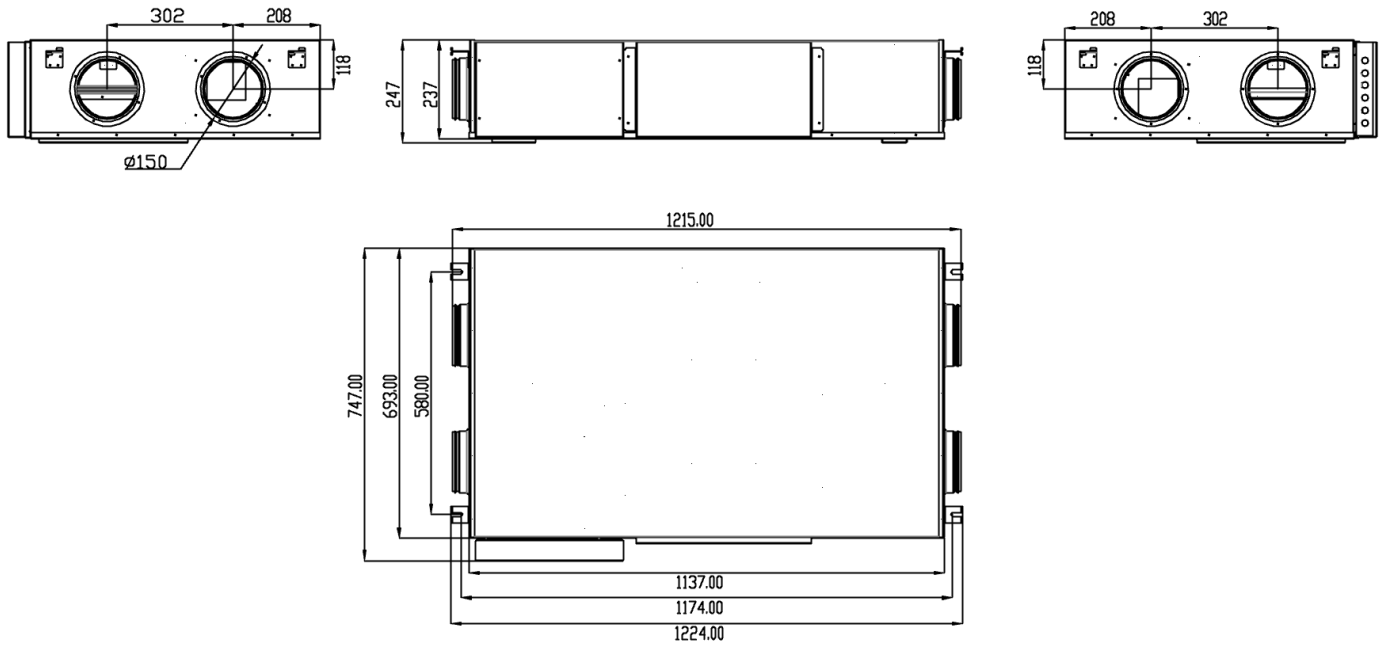

04/ MVHR INSTALLATION INSTRUCTION & OPERATION GUIDE

- Refer to the corresponding user manual of the control system for the CONTROL SYSTEM INSTALLATION INSTRUCTION & OPERATION GUIDE (power connection and control system wiring subject to model)

4.1 Recommendation for Installation

Things to Avoid for Installation

- ☒ Ventilation unit should not be installed in places where the ambient temperature exceeds 40 °C
 - Filter and heat exchanger will be deformed or motor will be damaged under high temperature
- ☒ Ventilation unit should not be installed in places with high humidity such as bathrooms
 - Electric shock or motor failure may be caused by the high humidity
- ☒ Ventilation unit should not be installed in kitchens and other places with a lot of oil fume
 - Excessive oil fume will block the filter and heat exchanger, resulting in the failure of the ventilation unit
- ☒ Ventilation unit should not be installed in production workshops, plants or other places with serious pollution
 - Chemicals, corrosive gases, oil mist or other harmful gases produced will cause damage to the ventilation unit

Arrangement of Air Ducts

- ☐ Installation and arrangement of air ducts should be horizontal or vertical
- ☐ Levelness of air ducts should be ensured as far as possible
- ☐ Arrangement of air ducts should be fixed with clamps every 1 meter to avoid the arrangement of ducts vibration
- ☐ Joints between the arrangement of air ducts and the ventilation unit should be fixed with tin foil tape
- ☐ Tape should be smooth and not wrinkled
- ☐ Joints should be tightly sealed to prevent air leakage
- ☐ Take sealing measures at the air duct connections of the ventilation unit to prevent air leakage
- ☐ Tin foil joints should be fixed with a tie
- ☒ Length of each ventilation arrangement of air ducts should not be way more than normally recommended
- ☐ Air ducts shall be made of non-combustible and flame-retardant materials for thermal insulation
- ☒ Air duct elbows shall be used as less as possible in the arrangement of air ducts
- ☒ Number of air duct elbows in each arrangement of ducts should be controlled
- ☐ Curved part of the duct elbow should be designed as a circular arc to avoid 90° right-angle bend

Regarding Electrical Heater

- ☒ Switch of the electric heater in the air duct should be interlocked with the switch of the ventilation unit
- ☒ Air ducts within a certain range before and after the electric heater shall be non-combustible materials
- ☐ Air ducts passing through the rooms with fire sources that are prone to fire shall be non-combustible materials

Arrangement of Air Inlets & Air Outlets

- ☐ Install the outdoor or indoor air inlet and outlet according to the specific air inlet and outlet
- ☐ Air resistance of the decorative air vents on the outdoor walls and indoor ceilings should be small
- ☒ Prevent the polluted air discharged to the outdoor drawn back to indoor by the fresh air inlet
- ☒ There shall be a certain distance between the air inlet and the air outlet installed on the outer wall
- ☒ Take sealing measures at the air inlet, outlet and air duct connections to prevent air leakage
- ☐ Air inlet and outlet should be on the diagonal in the room which meet the requirements of the design drawings
- ☐ Air inlet and outlet in the room should avoid to be installed at the dead corners
- ☐ Air flow at the air inlet and outlet should not be blocked as far as possible
- ☐ Outdoor fresh air and the indoor contaminated air should form and maintain a continuous air circulation system

4.2 Installation of the Ventilation Unit

Installation Positions

- Wall mounting (vertical) or wall mounting (horizontal) installation positions are possible
- Floor standing (vertical) or floor standing (horizontal) installation positions are possible
- Ceiling mounting (horizontal) installation position is possible

- Installation location and position of the ventilation unit must reserve sufficient space to access
 - Space shall be reserved for filters replacing, others servicing, repairing, maintenance and dismounting operation

Ceiling or Wall Mounting Installation

- Consider the material of the mounting surface as well as the weigh of the unit before mounting
 - Make sure the ceiling or wall has enough strength to carry the unit sustainably before ceiling or wall mounting
- Measure the four fixing positions of the ventilation unit (according to the chapter of **3.4 Overall Dimension**)
 - Confirm the drilling height and hole diameter on the ceiling or wall
 - Mark the drilling locations on the ceiling or wall
- Then use the corresponding twist drill to drill four related expansion screw holes
 - Lock the corresponding expansion screws into the ceiling or wall
- Hang the ventilation unit in the corresponding position on the ceiling or wall with the four fixing mounting brackets
- The using type of screws or rods and components depends on the need of actual construction site
 - Use nuts and washers at the four fixing mounting brackets to secure the ventilation unit on the ceiling or wall

4.3 Inspection before Trial Operation

- ☒ Check the ducting system against the engineering design drawings and this user manual
- ☒ Check whether the direction of the air duct is correct
- ☒ Check whether the ventilation unit is installed firmly
- ☒ Check other aforementioned precautions
- ☒ Check whether the installation position conforms to this user manual's relevant instructions
- ☒ Check whether there are debris or installation tools left inside or on the air duct or the ventilation unit
- ☒ Check whether the air inlet and the air outlet are installed securely

- ☒ Check the circuit system
- ☒ Check whether the diameter of the power input wire and control wire meets the requirements
- ☒ Check whether the connection method is correct
- ☒ Check whether the contacts are tightened

- Check the power supply according to the electrical connection diagram in this user manual
- Check whether the power supply voltage is within the normal range, that is, 230V~ power supply

4.4 The Ventilation Unit Commissioning

- Do not insert fingers or other objects into the air inlet or the air outlet of the ventilation unit during the trial operation
- If there is any abnormal phenomenon during the trial operation, cut off the power of the ventilation unit immediately
- If there is any abnormal phenomenon, contact the supplier to avoid danger
- Plug in the power supply, start up the ventilation unit
- Test the fans and check whether the ventilation unit works normally
- Check whether the ventilation unit operates smoothly

- Check whether there is abnormal vibration and sound
- If there are other abnormal conditions, shut down and check again
- ▣ The ventilation unit can be used normally if there is no abnormal operation
- ▣ When other indoor projects are not completed, do not use the ventilation unit for ventilation temporarily
- ▣ When other indoor projects are not completed, prevent indoor dust from entering inside the ventilation system

05/ FILTER & HEAT EXCHANGER MAINTAINENCE GUIDE

- Regular filtration configuration and heat exchanger maintenance is highly recommended in order to maintain the best ventilation and purification efficiency of the ventilation unit. Different filtration configuration and heat exchanger maintenance intervals are stated as followings (affected by actual environmental factors, the cleaning cycle and service life of the filter will be subject to change)
- Before maintenance takes place, clean your hands with hand sanitizer, wear a mask and gloves. Dispose of the used filtration configurations, mask and gloves into the hazardous waste sorting bin. After maintenance, clean your hands with hand sanitizer
- The ventilation unit must be equipped with filter for operation. Otherwise, the dust will block the heat exchanger, causing the ventilation unit failure

5.1 The G4 Supply Filter or Extract Filter Wash Cleaning & Replacement Guide

- Maintenance method (clean and replace)
- Recommended maintenance cycle (3 months)
- Wash cleaning of the G4 supply filter or extract filter is allowed
- After two consecutive times of wash cleaning the filter should be replaced
- Turn OFF the ventilation unit and disconnect the power supply before maintenance
- Note that the label of the module should be facing out when placing it back to its original position
- Gently brush with soft brush is allowed, do not use aggressive solvents, volatile oil and metal brush when cleaning the filter
- Do not wash the filter in hot water. Do not use open flame to dry, otherwise it will cause material deformation or damage
- Do not wet the fans, electrical components, heat exchanger or other devices with water during maintenance

□ Wash cleaning

Step 1: Unscrew and remove the service panel of the ventilation unit

Step 2: Remove the filter from the ventilation unit

Step 3: Rinse the filter with clean water, then dry its surface with soft cloth and dry it thoroughly under ventilated area

Step 4: Place the filter back to its original position (the original direction of the filter must be placed correctly)

Step 5: Place back the service panel of the ventilation unit and screw

□ Replacement

Step 1: Unscrew and remove the service panel of the ventilation unit

Step 2: Remove the filter from the ventilation unit

Step 3: Place a new filter back to its original position (the original direction of the filter must be placed correctly)

Step 4: Place back the service panel of the ventilation unit and screw

5.2 The F8 Supply Filter Vacuum Cleaning & Replacement Guide

- Maintenance method (clean and replace)
- Recommended maintenance cycle (6 months)
- Vacuum cleaning of the F8 supply filter is allowed
- After two consecutive times of vacuum cleaning the filter should be replaced

- Turn OFF the ventilation unit and disconnect the power supply before maintenance
- Note that the label of the module should be facing out when placing it back to its original position

□ Vacuum cleaning

Step 1: Unscrew and remove the service panel of the ventilation unit

Step 2: Remove the filter from the ventilation unit

Step 3: Clean the filter with a vacuum cleaner

Step 4: Place the filter back to its original position (the original direction of the filter must be placed correctly)

Step 5: Place back the service panel of the ventilation unit and screw

□ Replacement

Step 1: Unscrew and remove the service panel of the ventilation unit

Step 2: Remove the filter from the ventilation unit

Step 3: Place a new filter back to its original position (the original direction of the filter must be placed correctly)

Step 4: Place back the service panel of the ventilation unit and screw

5.3 The Heat Exchanger Vacuum Cleaning & Wash Cleaning Guide

- Maintenance method (clean)
- Recommended maintenance cycle (12 months)
- Vacuum cleaning of the heat exchanger is allowed
- Wash cleaning of the heat exchanger is allowed

- Turn OFF the ventilation unit and disconnect the power supply before maintenance
- The original direction of the heat exchanger must be placed correctly when placing it back to its original position

□ Vacuum cleaning

Step 1: Unscrew and remove the service panel of the ventilation unit

Step 2: Remove the heat exchanger from the ventilation unit

Step 3: Clean the heat exchanger with a vacuum cleaner

Step 4: Place the heat exchanger back to its original position

Step 5: Place back the service panel of the ventilation unit and screw

□ Wash cleaning

Step 1: Unscrew and remove the service panel of the ventilation unit

Step 2: Remove the heat exchanger from the ventilation unit

Step 3: Rinse the heat exchanger with clean water, then dry its surface with soft cloth and dry it thoroughly under ventilated area (clean with warm water or warm neutral detergent solution is allowed)

Step 4: Place the heat exchanger back to its original position

Step 5: Place back the service panel of the ventilation unit and screw

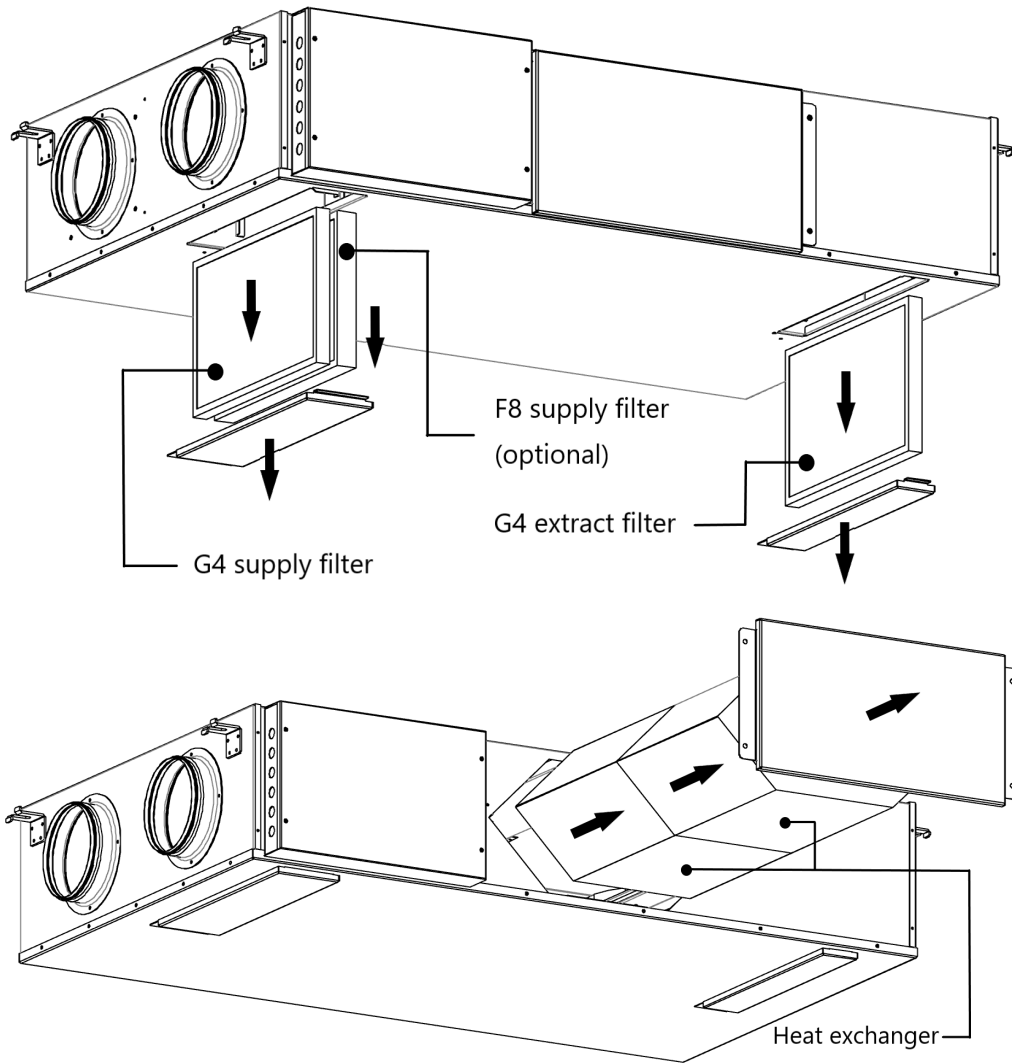

- Ⓜ If you have any specific problems during the use or maintenance of this product, contact the supplier or the maintenance department. Measures shall be taken after approval, otherwise the company will not be responsible for the consequences caused by the user's unauthorized changes
- Ⓜ The company will not bear any responsibility for the adverse consequences caused by the user's modification of the ventilation unit or the electronic control system without the permission of the company
- Ⓜ Due to the failure to install or use the ventilation unit as required, the company will charge corresponding fees for the after-sales service

- The contents of this user manual and the specifications of this product are subject to change without prior notice
- Download the latest user manual from www.e-vipo.com
- Contact us if you have questions regarding the configurations of this product

- The schematic diagram in this user manual is subject to the actual object

WARNING: DO NOT DISPOSE THE VENTILATION UNIT OR THE CONTROL PANEL OR THE ACCESSORIES IN DOMESTIC WASTE. PART OF THE PRODUCT MATERIALS CAN BE RECYCLED AND PART OF THE PRODUCT MATERIALS SHOULD NOT BE DISPOSED IN DOMESTIC WASTE. AT THE END OF THE SERVICE LIFE OF THE PRODUCT, PLEASE DISPOSE ACCORDING TO THE RELEVANT NATIONAL REGULATIONS

VIKA INTELLIGENT TECHNOLOGY (GUANGDONG) CO., LTD.

Vika Industrial Park, Nanlang Industrial Base, Nanlang Street, Zhongshan City, Guangdong Province, China

www.e-vipo.com

E-ViPO®